

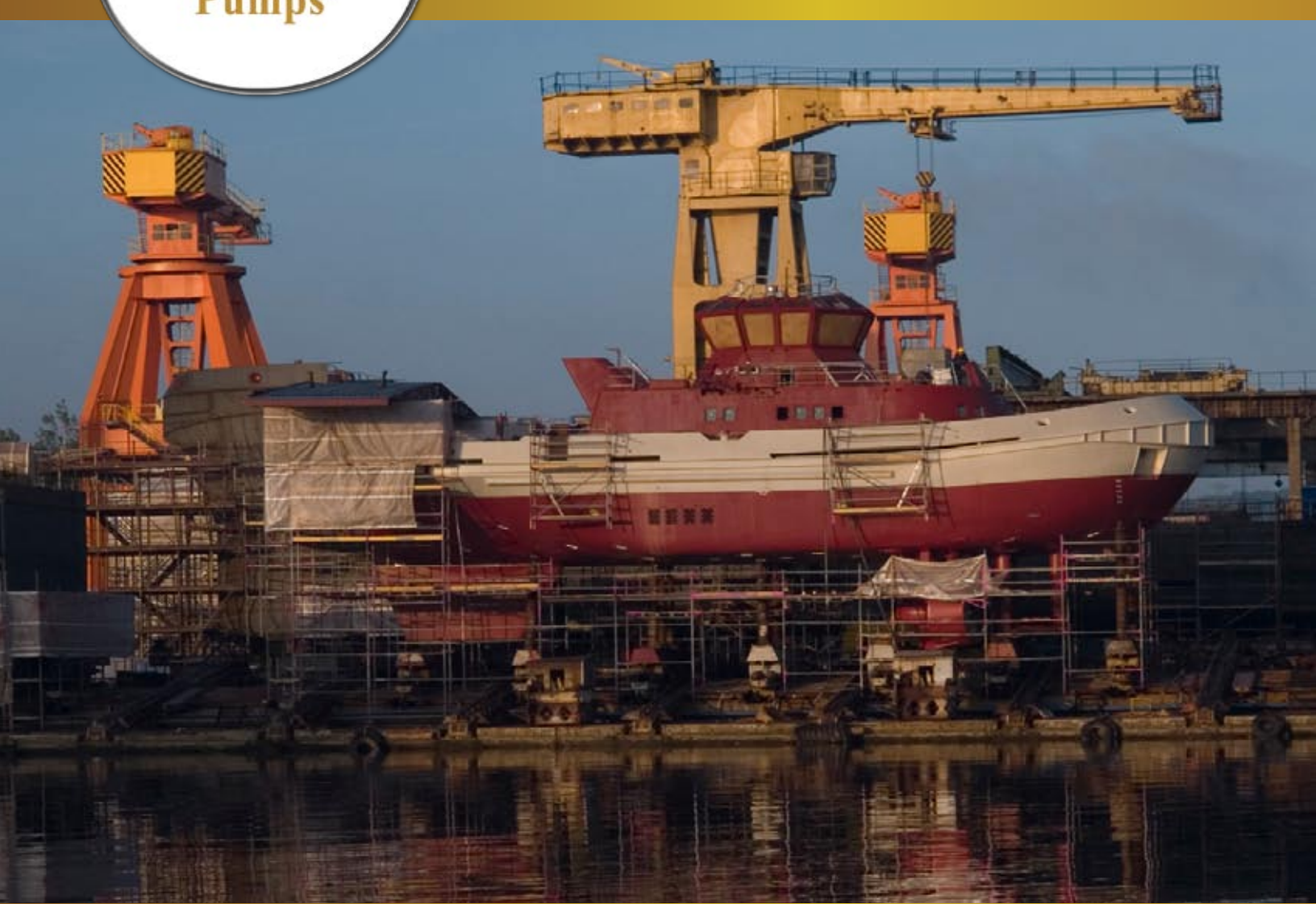

# Commercial Marine Pumps and Systems



## Pumps and Packaged Systems for Commercial Marine Applications and Heavy Industries

- Engine Room Pumps
- National Defense
- Pump Outs
- Shipbuilders
- Shipyards
- Yacht/Ship Refinishing

# Introduction



## Battlefield Tested for Commercial Marine Applications Your Applications Are Diverse, So Are Wastecorp Pumps.

Wastecorp's commercial marine pump division serves the needs of cruise ship operators, shipbuilders, dry dock services companies, oil rigs, University marine biology research departments, yacht builders and worldwide Naval defense agencies. From engine room booster, circulation and seawater transfer pumps to pump out and bilge pumping services, Wastecorp is your full service OEM commercial marine pump manufacturer.

### More Choice At Wastecorp Pumps

Wastecorp can help you customize your pump with components that are designed for the long haul which

maximizes your budget. This includes our award winning Mud Sucker Pump brand with a choice off over 100 diaphragm pump models for severe duty pumping. Contact a Wastecorp engineering support representative for more information at **1-888-829-2783** or **+1-201-445 2882** worldwide.

### Heavy Duty Internals

If you're like many commercial marine customers, you're looking for a pump system that can outlast the punishing conditions of your application. Unlike most makes, Wastecorp Pumps feature heavy duty internals that can withstand severe duty applications.

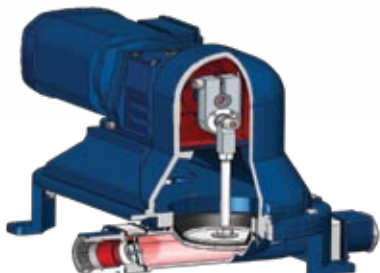
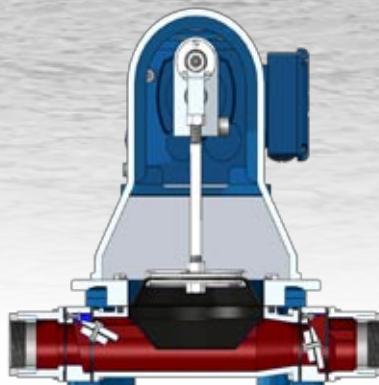

### Innovation Built-in

Wastecorp's innovative flex production floor enables you to select specific components designed for your application with reduced wait times for specialty pump products. Get the pump you need without the wait.

# Commercial Marine Pump Products

## Waste Tank Pump Systems

For temporary bilge and waste transfer services into a container, Wastecorp's marine waste tank systems are available in a variety of configurations.



- Select up to 2000 gallon translucent polyethylene, stainless steel, or steel tanks
- Heavy duty Mud Sucker 2FA Series pump systems
- Crush proof hosing

• [Click to visit Visit Wastecorp Waste tank pumps](#)

## High Volume Centrifugal Pumps

Turbo Flow high volume pumps are offered in split case, circulation/booster and end suction pump models. Designed for marine ballast, seawater cooling pumps, fresh water cooling pumps, circulation applications and more.



- Fluid transfer capabilities up to 60,000 GPM
- Various materials of construction available
- Heavy duty pump design

• [Click to visit Wastecorp's high volume pumps.](#)

## Positive Displacement Piston Pumps

Wastecorp positive displacement piston pumps are widely used on offshore oil rigs for pumping oil sludges, chemicals and raw sewage.



- Pump up to 550 GPM
- Simplex-quadruplex piston models available
- Select from engine or electric models with premium Siemens drive systems

• [Click to Visit Wastecorp Piston Pumps](#)

## Heavy Grit and Waste Oil Pumps

Designed for shipbuilders and shipyards, the heavy duty double diaphragm and ball valve pump systems from Wastecorp transfer the heavy duty grit laden applications of hull refinishing and overhaul jobs.



- Select from 2"-4" connection models
- Internals available for corrosive fluids and debris laden liquids
- Specialty components designed for specific applications.

• [Click to Visit Mud Sucker Diaphragm Pumps.](#)

## Clean Water Distribution Pumps

Fresh water distribution systems are available in complete packages for cruise ships, cargo ships, Naval ships and carriers.



- Potable and non potable units available
- Selection of tanks up to 2500 gallons in a variety of materials
- Mobile and skid mounted water distribution systems available.

• [Click to learn more about Wastecorp water distribution systems](#)

## Pump Outs

Wastecorp's versatile pump outs can transfer brackish water, viscous asphalt, molasses, waste oil, bilge waste and more. These pump outs are designed for tanker unloading, supply pumps and can transfer no. 2-6 oils.



- Explosion proof motors available
- Contoured velocity channel for pumping tough fluids
- Mobile and stationary models available.

• [Click to learn more about Wastecorp commercial marine pump outs](#)



## Customers Say...

“We work the heck out of the Mud Sucker 3FA-Series with our advanced hull blasting process. We've used other pumps but our Mud Sucker 3FA-EC works better.”

**Detyens Shipyards -  
Charleston, South Carolina**

## Sample Customers

- American Custom Yachts Inc. Stuart, FL
- Carnival Corporation Miami, FL
- Discount Boat Storage Muskoka, Canada
- China Petroleum and Chemical Corporation (Sinopec)
- Dubai Ports World Jebel Ali, Dubai
- Hyundai Heavy Industries, Ltd. - Uldan, South Korea
- Stream Tek Waterjet Fort Wayne, Indiana
- US. Army Corps of Engineers New Orleans, LA
- University of Florida Gainesville, FL
- US Navy Submarine Base CT, USA
- Waterway House Boats Sicamous, British Columbia

**Our pumps are designed for one application.**

**Yours.**

With less time to fulfill customer deadlines, you need a dependable pump or sanitation system that works as hard as your team. Wastecorp commercial marine pump products help shipbuilders, defense contractors, government and small businesses meet the challenges of pumping tough fluids with long life cycles. Experience Wastecorp commercial marine products today, available worldwide.



**Wastecorp®  
Commercial Marine Pump Division**

**Toll-Free North America  
1.888.829.2783**

**Website  
<http://www.wastecorp.com>**

**Worldwide  
+1.201.445.2882**

**E-mail  
[info@wastecorp.com](mailto:info@wastecorp.com)**

Commercial marine specifications, literature and illustrative material are accurate at the time of publication but are subject to change without notice. Illustrations may include optional equipment and accessories and may not include all standard equipment. Wastecorp and globes are trademarks of WPCI Environmental Brands.

© 2010 WPCI Environmental Brands.

NYC/ DSO Worldwide      Lithographed in the United States of America

For a complete engineering specification contact Wastecorp at 1.888.829.2783 or by E-mail: [info@wastecorp.com](mailto:info@wastecorp.com)