

Wastecorp Mud Sucker® 1.5B-M™/2B-M™ Series



Applications

- The ideal multipurpose pump designed for medium debris laden applications.
- Widely used for biofuels, vegetable oils, waste oil, light sewage, marine and recreational applications.

Benefits

- Available with a 1½" or 2" connection.
- Solids handling up to 1½".
- Exclusive Wastecorp design.
- Few moving parts for low cost of ownership.
- Specialty drive systems available including DC motor (shown above).

Performance Range

Max. capacity	20 GPM
Max. suction lift	20' vertical or 75" horizontal
Max. discharge head	50' vertical or 300' horizontal
Solids handling	1½" dia or 50% by volume

Pump and Motor Specifications

Suction inlet/outlet size	1.5" or 2"
Max. liquid temperature	140° F (60° C) continuous
Pump body casing	Marine grade aluminum (ASTM A356, Class 30)
RPM speed of diaphragm	61
Diaphragm	7" dia. fabric reinforced Buna-N
Ball valves	2"
Gearbox	SEW Eurodrive or Siemens - cast iron housing with heat treated gears
Hardware	Stainless steel 316
Rod end bearing body	Carbon steel, protective coated for corrosion resistance
Ball bearing	Sintered steel, heat treated, oil impregnated
Ultimate radial static load capacity	9,000 Lbs
Motor specification	3 hp Honda GX-100 engine with manual recoil start



Heavy duty connections help you get your job started fast and last longer.

Combine the high performance Mud Sucker B-Series Professional with Honda's GX engines and you get a winning pump for solids handling applications.

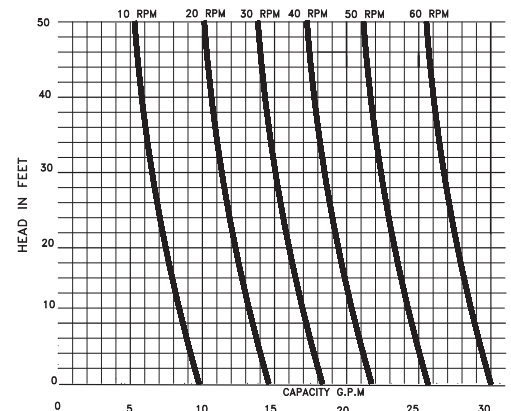

1.5/2B-M dimensional drawing

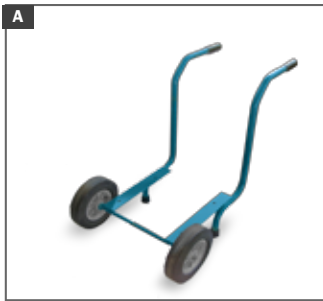
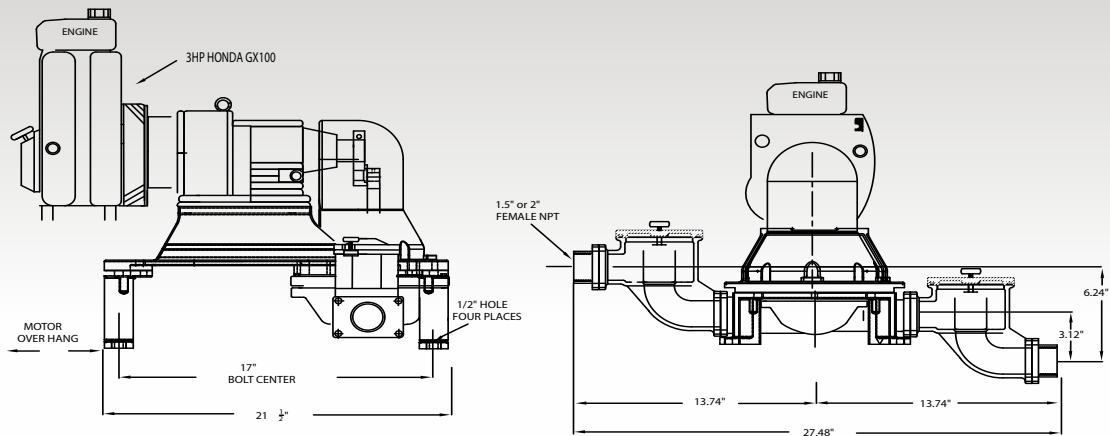

Wheel kit



The Gulper™ suction tool



Boxed pump out hose assembly

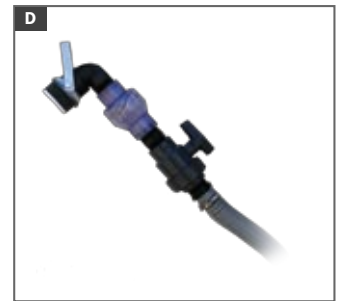

Universal RV adapter

Accessories

A	Wheel kit	61315-00
B	The Gulper™	60506-00
C	Boxed pump out hose assembly	61020-00
D	Universal RV adapter	60710-00
	Suction hose (non collapsible)*	Various sizes
	Discharge hose (lay flat)	Various sizes

* Premium non-collapsible suction hose assemblies include aluminum camlock fittings. Contact factory for desired length.

Recommended Spare Parts

2" ball valve	MS1099-B
Diaphragm	60444-02



Wastecorp Pumps
 PO Box 70
 Grand Island, New York 14072
 Tel: 888-829-2783 Fax: 888-883-3320
 Email: info@wastecorp.com

wastecorp.com

© 2009 Wastecorp Pumps. All rights reserved. Mud Sucker/ pump designs are protected by domestic and international patents and/or copyrights.