



## Mud-Sucker® Diaphragm Pumps - The Pump With Attitude

### Air Driven Diaphragm Pumps

#### Mud-Sucker® Air Driven Diaphragm Pump Series

- Self-priming with solids handling models available
- Patented contoured velocity channel with one piece pump body
- Run-dry capabilities without damaging pump
- Mud-Sucker air driven pumps can transfer corrosive and viscous media
- Designed for simplicity of use
- 1.5"-3" models available

Shown:

*Mud-Sucker® 3FA-AP™ with self-lubricating reciprocating air cylinder, 6" bore x 3" stroke, and adjustable solenoid. Air motor is mounted and supported vertically over the pump body, with a heavy-duty 13" dia diaphragm, 3" stroke length. Features an aluminum check valve seat with single flapper check valve construction with upper and lower weights to ensure positive seating on both suction and discharge.*

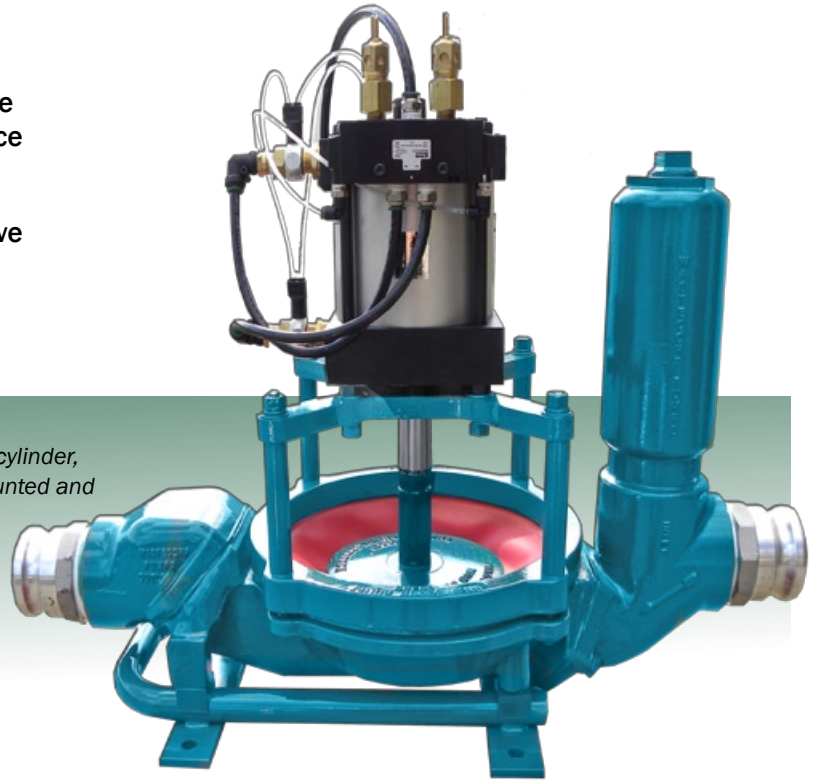

#### Model Selection

##### MS-1.5AP™

- 1 1/2" x 1 1/2"
- Flow up to 18 GPM
- Head up to 50 TDH
- Air consumption – 8 ACFM\* at 50 cycles/min at 85 PSI

##### MS-2AP™

- 2" x 2"
- Flow up to 25 GPM
- Head up to 50 TDH
- Air consumption – 12 ACFM\* at 50 Cycles/min at 85 PSI

##### MS-3AP™

- 3" x 3"
- Flow up to 80 GPM
- Head up to 50 TDH
- Air consumption – 35 ACFM\* at 56 cycles/min at 85 PSI

#### Dimensions 3" Model

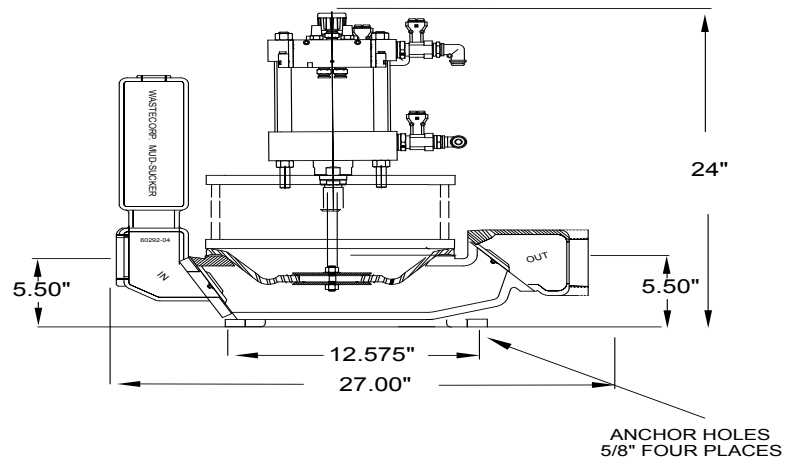

Technical Support: 1-888-829-2783 • Fax: 1-888-883-3320  
E-mail: [info@wastecorp.com](mailto:info@wastecorp.com) International Sales/Support: +1/201/445-2882