



Mud Sucker® Diaphragm Pumps - The Pump With Attitude

Double Diaphragm Pumps - Solids Handling

Mud Sucker® B-DD Series

Mud Sucker ball valve style double diaphragm pumps are designed for high content solids and heavier slurry applications for government and industry. Food Processors, international mining companies, municipalities, Military bases and large farms have found success in transferring tough solids for demanding application

Select from engine or electric driven models with premium components designed for the long haul.

Performance Range	3" / 4"
Max. capacity	160 GPM / 220 GPM
Max. suction lift	25' vertical or 100' horizontal
Max. discharge head	50' vertical or 500' horizontal
Solids handling	2¼" dia or 50% by volume

Pump and Motor Specifications

Suction inlet/outlet size	3" x 3" NPT/4"x4" NPT
Max. liquid temperature	210 °F (99 °C) continuous
Pump body casing	Cast iron (ASTM A48, Class 30-35)
Diaphragm	14-3/4" dia thermoplastic elastomer (red) Severe duty -25 °F to 212 °F Optional: Neoprene
Ball valves	5-1/8" diameter polyurethane with steel core
Gearbox	Helical bevel parallel gear reducer, SEW Eurodrive or equal
Clamping ring	Cast iron (ASTM A48, Class 30-35)
Clamping plate	Cast iron (ASTM A48, Class 30-35)
Valve seat	Cast iron (ASTM A48, Class 30-35) Optional bronze or stainless steel
Sampling valve	1" bronze quick opening sampling ball valve
Pump Shaft	2" double output shaft
Hardware	Zinc plated
Rod end bearing body	Cast iron, protective coated for corrosion resistance
Bearing	Needle ball bearing with inner ring
Fitting	Alemite grease fitting
Shaft	Carbon steel 1040
Motor Specification	7.5 hp; 1800 RPM, 3 hp; 60 Hz; 230/460V TEFC SEW Eurodrive constant speed helical gear motor.



BDD-EC Electric

Guard removed for clarity



BDD-M Engine Driven Auto-Start

B-DD Standard Design

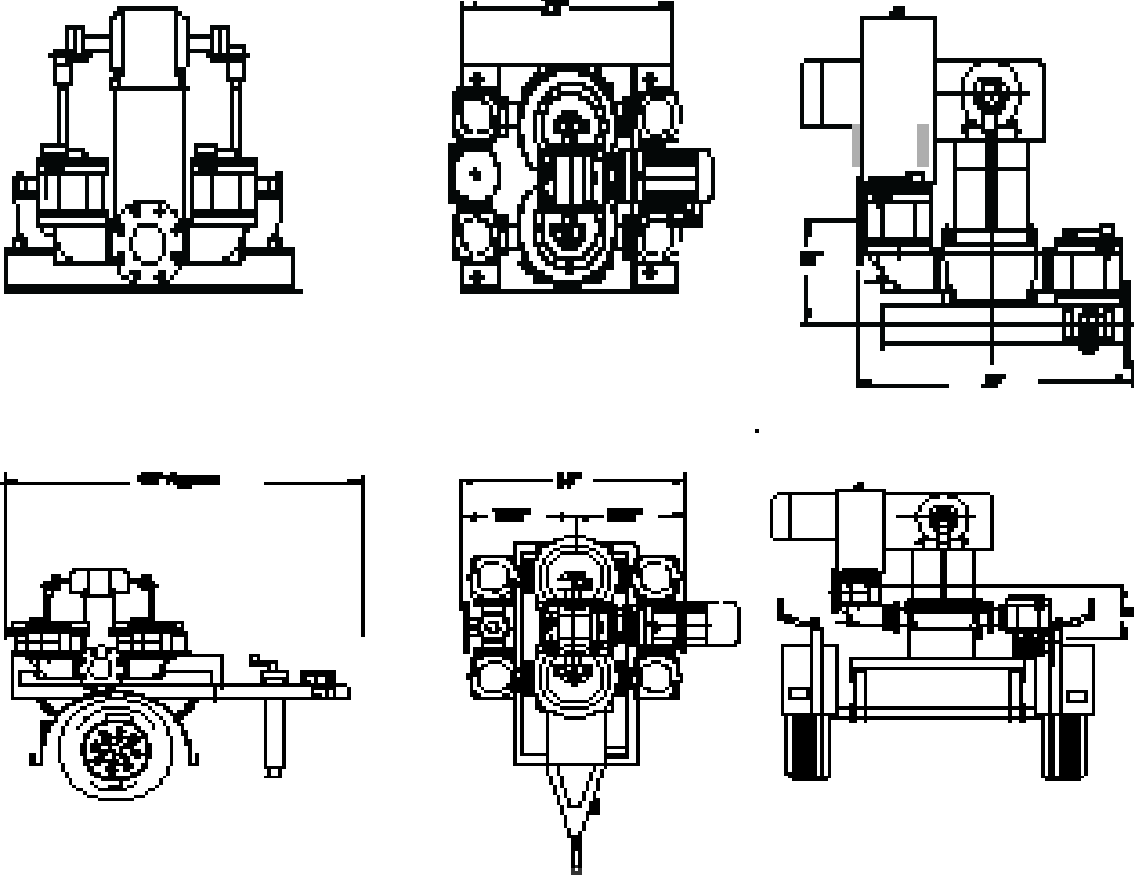

B-DD Performance Curve

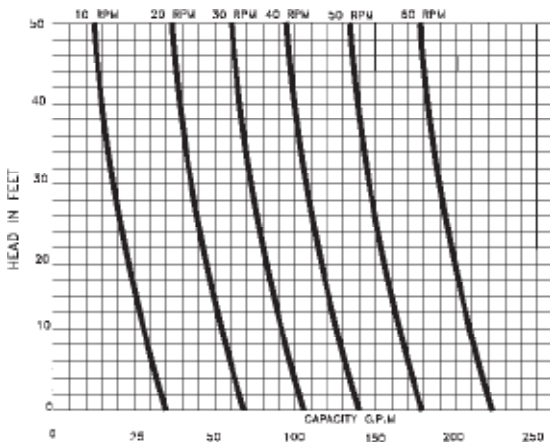

Recommended Spare Parts

Diaphragm	16369-00
Valve seat (cast iron)	36022-02
Machine screws	33216-00
Valve seat gasket	36026-00
Valve seat (cast iron)	61166-00
Bearing rod end ass'y	36022-02



Technical Support: 1-888-829-2783 • Fax: 1-888-883-3320
 E-mail: info@wastecorp.com International Sales/Support: +1/201/445-2882