



## Trash-Flow® Centrifugal Pumps

### TFCC Series™

### Self Priming Centrifugal Pumps - Direct Replacement

### Trash-Flow® TFCC Series™ 3”

The Trash-Flow TFCC Series is Wastecorp’s direct replacement product line for most brands of self priming centrifugal pumps.

#### Specifications

Max. Capacity	460 GPM (104.477 m3/hr.)
Max. Head	115 ft. (35.052 m)
Max. Temp.	160° F (71° C)
RPM Range	650 - 2400

#### Materials of Construction

Main Casing	A48CL30
Impeller	A60-40-18
Wear Plate	SAE1020
Cover Plate	A48CL30
Bearing Housing	A48CL30
Seal Plate	A48CL30
Flapper Valve	Neoprene
Shaft Sleeve	ANSI 4140HT
Inlet/Outlet Flanges	A48CL30
Gaskets	Buna
Impeller Shaft	ANSI 4140HT
Mechanical Seal	Oil-Lubricated Double Floating, Casing and spring SS316, O’rings in Buna & Viton, Faces in Titanium and Tungsten Carbide



#### Typical Applications

- Waste Treatment (scum pits, lift stations, digester recirculation, slurry).
- General industrial water and wastewater transfer.
- Pulp and Paper (wood yard and processing plant sumps, chip and light pulp handling .
- Food Processing & Rendering (fruit & vegetable waste, beef, poultry and seafood waste parts, flushings, hide, light fat).

**Performance Curve**

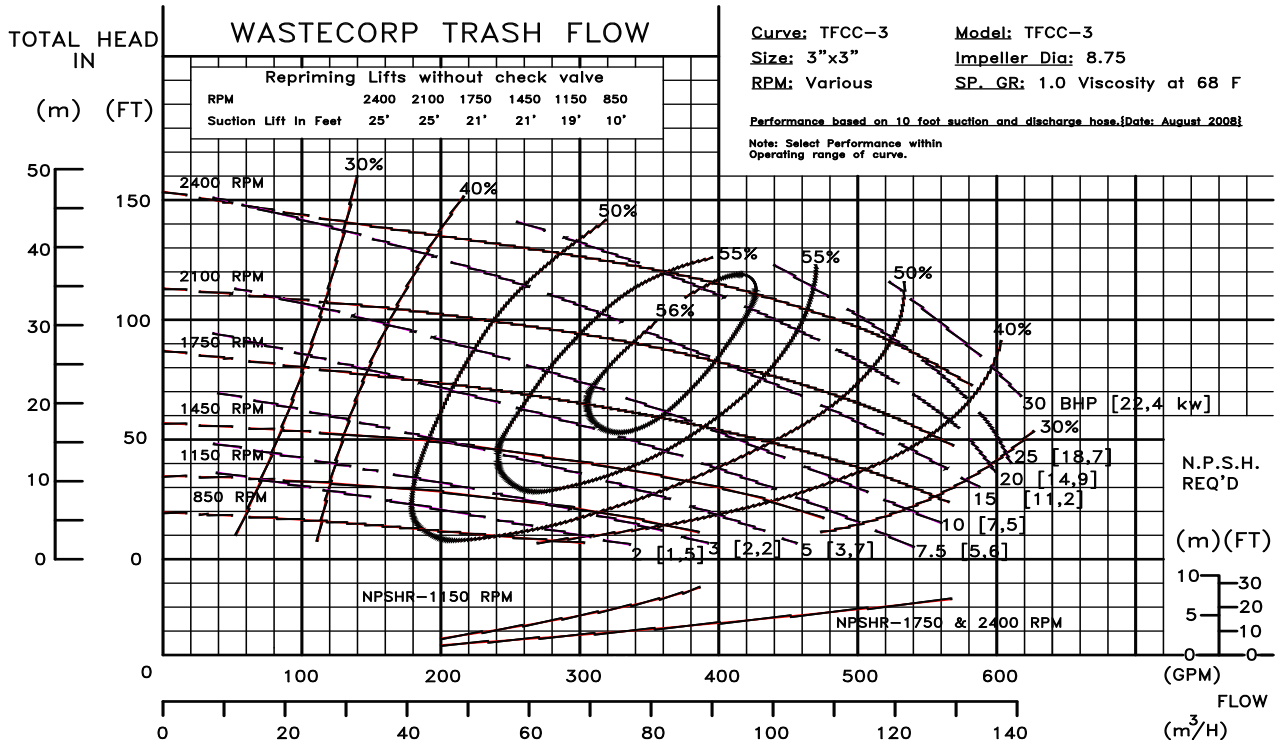

**Pump Dimensions**

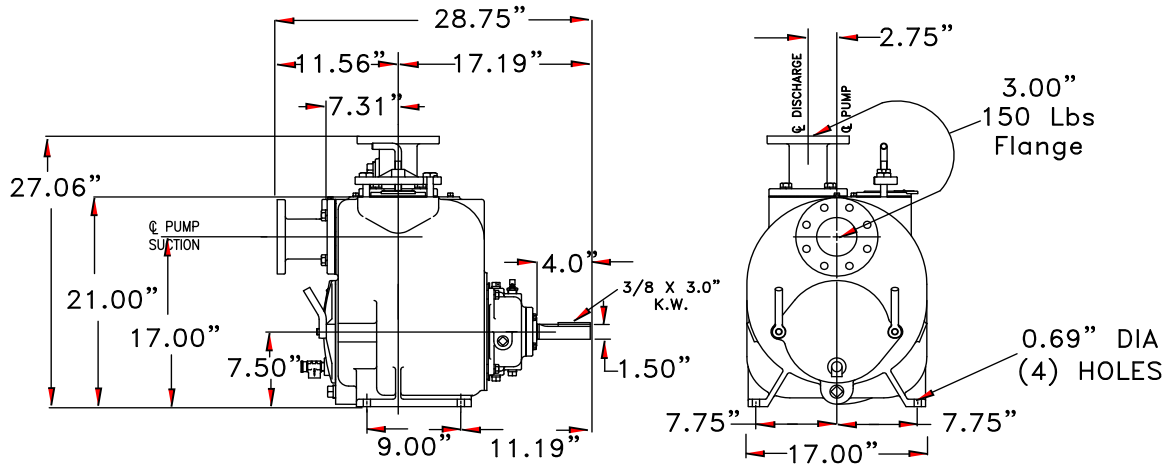

**NET WEIGHT: 425 LBS**



Technical Support: 1-888-829-2783 • Fax: 1-888-883-3320  
 E-mail: info@wastecorp.com International Sales/Support: +1/201/445-2882